

Titan Mini-Recorder

BMS User Manual



Proprietary Notice

This information is furnished for installation, operation, test and maintenance purposes. The information is proprietary in nature and should be treated accordingly. The data shall not be released or used, duplicated or disclosed, in whole or in part, for manufacture or procurement without the written permission of **Mars Labs**.

Copyright

This Technical Manual is copyright © 2017. All rights reserved. Brief excerpts may be made from this manual for technical purposes, as long as they are referenced.

Although this manual is believed to be correct at the time of publication, **Mars Labs**, its employees, or agents involved in the preparation and publication of this manual do not accept any form of liability for its contents or any consequences arising from its use. People using the information contained in this manual should apply, and rely upon, their own skill and judgement to a particular issue which they are considering.

Warning

Only a qualified technician or representative of Mars Labs should attempt to service the components of this system. There are no user-serviceable parts inside.

For safety and protection of the equipment, power must be turned off prior to connecting or disconnecting cables and sensors.

**Titan BMS Mini-Recorder
User Manual v7.4
MNL 1009
March 2017**

Table of Contents

Introduction

Furnished Accessories	4
Support	4
General Guidelines and Warnings	5
Guidelines for Wiring Sensors	6

Operation

Front Panel	7
Rear Panel	10
Signal Flow	11
Sensor Interface	12
Calibration Modes	13
Formatting Memory Cards	14

Interface

Analog Input Connector (DB9F)	16
COMM Port	16
GPS Port	17
REM (Remote)	17

Sensor Connection Examples

Full Bridge Sensor	18
Half Bridge Sensor	19
Quarter Bridge Sensor	20
Platinum RTD Sensor	21
Voltage Sensor	22
ICP Sensor	23
String Pot Sensor	24
RVIT Sensor	25
Frequency Sensor	26
Thermocouple Sensor	27

Theory and Operation of Thermocouples

28

Per-Channel Excitation

30

Features & Specifications

Key Features	33
Specifications	33
Supported Sensors	34
Titan Nomenclature	35

Asset Tag/Customer Information Data Entry

36

Troubleshooting

38

Warranty & Repair

41

Notes & Known Issues

42

Introduction

The Titan BMS Mini-Recorder is a fully integrated data acquisition system that features a 16-channel interface with on-board signal conditioning, programmable gain, excitation and filtering, A/D conversion, and built-in data storage capability via an SD memory card data recorder. The Mini-Recorder is powered by a USB ‘Y’ cable when connected to a PC, or from the front panel auxiliary power connector with an external supply. A remote recording jack permits cabled remote control of the recording function. An Auxiliary Digital Input supports either a GPS sensor or Titan Digital Pod, and an expansion slot offers additional functionality via optional expansion cards.

This manual is intended to provide an overview of the Titan BMS Mini-Recorder, with complete feature descriptions, specifications, setup procedures and operational information. It contains important safety information as well.

Furnished Accessories

The Titan Mini-Recorder is typically shipped with the following items:

1. Titan BMS Mini-Recorder
2. USB or Serial Cable
3. SD Memory Card

A Titan Power Adapter or a mating connector for the Mini-Recorder Auxiliary Power Connector may also be included.

Support

Support for this product is available by contacting the factory during regular business hours (9am – 6pm EST) at 301-470-3278. Additional information can be found on our web site: <http://www.marslabs.com>

General Guidelines and Warnings

Electrostatic Discharge

Electrostatic Discharge (ESD) occurs when a static charge builds up on either yourself or the Titan hardware, and then you touch the Titan hardware. The static spark can be so small that you don't feel it, however, it can flaw a semiconductor. These flaws may generate an immediate failure, or, in most cases, cause a slight reduction in performance which will continue to degrade, eventually leading to failure of the hardware. When you feel a static shock, you are experiencing a minimum of 3,000 volts of electricity.

Even though the input connectors have protection to prevent ESD damage, it is good practice to always ground yourself and the Titan hardware while connecting and removing sensors.



Always use approved ESD handling procedures to prevent ESD damage.

Grounding Titans

In general, grounding the Titan hardware to the test vehicle or test structure will usually reduce noise pickup.

All of the analog inputs of the Titan hardware have a return path to ground. However, it is very important that each sensor have only one return path to avoid ground loops. When testing a vehicle, often the vehicle chassis and Titan can have very large ground imbalances of one or two volts. In such situations, ground the sensors to Titan and use differential inputs across the sensor. A totally floating input (like a 9-Volt battery) must have one side grounded at the point where used, either grounded to Titan or connected to the vehicle chassis ground via a resistor (e.g. 10K ohm).

If there is a possibility that a floating sensor may be occasionally grounded, install a 10K ohm resistor from the minus input to Titan ground. When the sensor is floating, the 10K ohm resistance will reference it to Titan ground, and when it is grounded, the resistor will allow the direct minus input wire to reference the remote chassis ground.



Specific Warnings

1. When using a power adapter with the Titan, always connect the adapter to the Titan before applying power. Never hot plug a Titan device under any circumstances - hot plugging may damage the device!
2. Under no conditions should the 12V and 5V lines on the Titan hardware be shorted together or connected directly to ground.

Guidelines for Wiring Sensors

Observe the following guidelines when wiring and connecting sensors to the Titan hardware:

1. Observe polarity of sensor wires
2. Strain relieve all connections
3. Secure cables with wire ties and bundle cables where possible.
4. Secure DB9 connectors by fastening to the Titan chassis
5. For Thermocouples, apply heat shrink to exposed wires
6. Double check all connections prior to connecting the cables to the Titan.
7. Use only heavy gauge CAT-6 shielded cables with locking tabs when connecting to the Titan CPU.
8. When routing cables, be aware of sharp edges and pinch points where cables can bind, or be cut, introducing shorts in the wiring

Operation

Front Panel

The Titan BMS Mini-Recorder front panel features an SD Memory card slot, a CONTROL toggle switch to initiate remote recording and select calibration modes, and connections for USB, GPS, and Auxiliary Power.



Auxiliary Power Connector

The Auxiliary Power Connector is used to power the Titan Mini-Recorder for remote applications (such as in-vehicle testing), or whenever excitation voltage is needed to power sensors (USB power alone is insufficient to both power the device and provide excitation). The Auxiliary Power Connector pinout is shown below. The voltage that is applied to Pin 2 (V+) is the operating voltage of the Mini-Recorder (the operating voltage appears on a label on the side of the device nearest the power connector). The voltage that is applied to Pin 4 appears as a secondary voltage source on all 16 Analog Input Connectors (see page 16).

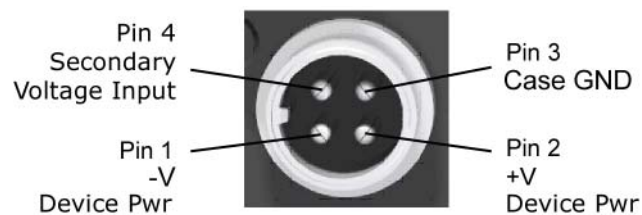

WARNING: When using a power adapter with a Titan device, always connect the adapter to the device before applying power. Never hot plug a device under any circumstances - hot plugging may damage the device!

NOTE: The mating connector for 4-pin Auxiliary Power input is available from Mars Labs as MLCON10227, and also from the following sources:

Radio Shack - P/N 274-001

Description: 4-Pin Female CB and HAM Radio Microphone Plug

Philmore - P/N 61-604

Description: 4-Pin Inline Female Mobile Connector

SD Card Slot

The Mini-Recorder accepts Ultra II, Extreme III, or Class 10 SD cards. Make sure to have an SD memory card inserted prior to initiating recording or configuring tests in the Titan Control Software (TCS) application. In order to create a test header file on the SD card, you must configure a test in TCS prior to recording. This is done by creating a new test in TCS, connecting to the Mini-Recorder, configuring the sensors, and initiating a Scan. For more information, consult the TCS User Manual.

NOTE: *If you are using memory cards other than the one supplied, those cards must be formatted prior to use. See page 14 for the procedure on formatting memory cards for the Titan Mini-Recorder.*

CONTROL Switch

The CONTROL switch is a multi-function toggle switch that is used to initiate manual recording and select calibration modes. LEDs to the left and right of the switch indicate the current status of the CONTROL modes.

Stop Mode – The red STOP LED indicates that the Mini-Recorder is not in record mode. If no SD memory card is inserted, the STOP LED will blink continuously. When an SD memory card is inserted, the LED will be illuminated solid.

Record (REC) Mode – The green REC LED is illuminated when the Mini-Recorder is recording. To enter record mode, move the toggle switch to the ‘REC’ position and release. To exit record mode, move the toggle switch to the ‘REC’ position a second time and release.

NOTE: *When in use, a Remote Recording Switch will override the recording function of the CONTROL switch. For more information on remote recording, see ‘REM’, page 19.*

Calibration (CAL) Modes – The Mini-Recorder offers three calibration modes: ‘CAL-’, ‘CAL+’ and ‘CAL 0’. ‘CAL-’ is indicated by a red LED, ‘CAL+’ is indicated by a green LED, and ‘CAL 0’ is indicated by both red and green LEDs. When any of these LEDs are lit, the Mini-Recorder is in CAL mode. To engage CAL mode, move the toggle switch to the ‘CAL’ position and release. Successively toggling the switch will cycle through the CAL modes as follows:

CAL- → CAL+ → CAL 0 → CAL OFF

For more information, see ‘Calibration Modes’.

USB Port

A USB Type B port that provides a communication link between the Mini-Recorder and the Titan Control Software (TCS). The port also supplies power to the device through the provided USB ‘Y’ cable.

NOTE: *Mini-Recorders require two USB ports to meet the base power requirement with no sensors driven. When sensor excitation is enabled, however, the USB connection alone cannot supply sufficient power to the device. Under these conditions, external power must be applied through the Auxiliary Power connector.*



If you are using a Windows 7 or Windows 8 PC and are experiencing USB connectivity issues, Mars Labs recommends updating your firmware to the latest version that is appropriate for your device. Contact the factory for more details.

GPS Port (Auxiliary Digital Input)

A multi-function port that accepts either a GPS sensor (a Garmin 18X-5Hz) and/or auxiliary serial data from digital sensors. GPS sensor support is an optional feature on the Titan Mini-Recorder.

Rear Panel

The Titan BMS Mini-Recorder rear panel features two LED status indicators, a communications (COMM) port and a remote (REM) jack:

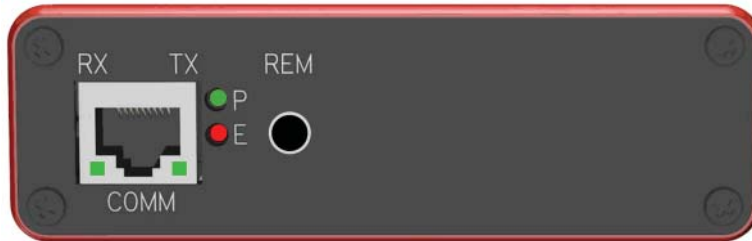

Status Indicators

P (Power) – A green LED indicating that the Mini-Recorder is ON.

E (Error) – A red LED indicating that a sensor output has meet or exceeded the range for the configured sensor channel as displayed on the TCS ‘Tags & Channels’ screen. If the input exceeds this amount, either positive or negative, the Error LED will be lit for as long as the input exceeds the maximum range. When the input signal falls back into the acceptable range the Error LED will go out. Note that the Error LED will be lit for *any* channel that exceeds the maximum range. If you are viewing signals in the Runtime screen in TCS, the signals will be clipped when they exceed the maximum allowable input.

COMM

An RJ-45 port used to interface the Mini-Recorder with the Titan CPU Channel Multiplexer and other expansion options. Integrated LEDs in the connector (RX & TX) indicate when the Mini-Recorder is receiving or transmitting data through this port.



NOTE: For information on configuring the COMM port for communication with TCS instead of the USB port, refer to ‘Running with RS-422’ in the TCS User Manual.

REM

An 1/8” TRS connection that provides remote Start/Stop recording.

Signal Flow

The diagram below shows the basic signal flow of the Titan BMS Mini-Recorder for a single input channel. The Titan Mini-Recorder supports 16 channels at up to 1200 samples per second (low speed operation), or up to 10,000 samples per second (high speed operation).

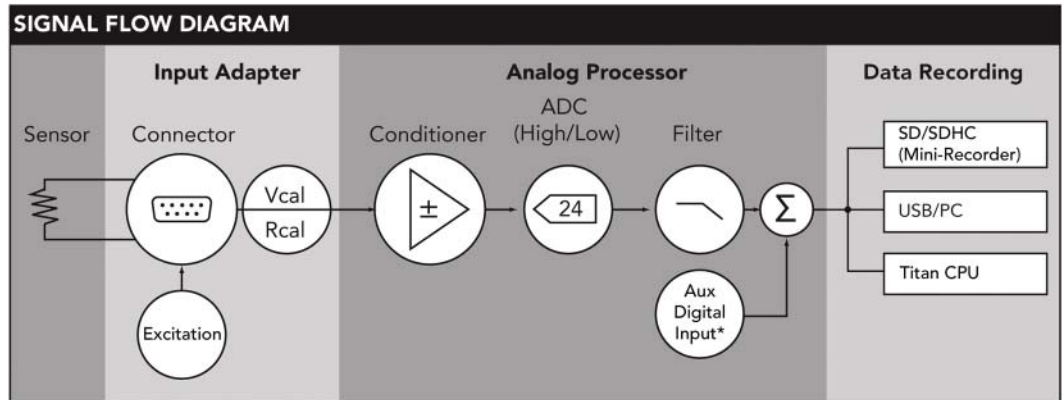

The Titan Mini-Recorder features on-board signal conditioning, programmable gain and filtering, and A/D conversion. Each channel features Programmable Excitation, sensor Balance** and Calibration loopback functions (RCal and VCal) to facilitate ease of setup and ensure data integrity. All channels have individual input amplifiers to achieve high accuracy, high inter-channel isolation, and low temperature drifts. Data recording options include recording directly to a PC (via USB), to a Titan CPU Channel Multiplexer, or internally to an SD memory card.

* The Auxiliary Digital Input supports either a Garmin GPS 18X-5Hz sensor or a Titan Digital Pod. The input is labeled 'GPS' on the front panel.

** Balance is a function that removes channel offsets. It is configured and controlled via TCS. For more on the Balance function, consult the TCS User Manual.

Sensor Interface

The sensor interface is implemented on sixteen DB9F connectors. As shown below, each DB9F connector provides programmable excitation, bridge completion for quarter bridge and half bridge sensors, an auxiliary voltage for custom applications, and ICP sensor support. To accommodate large input signals, each channel features an input divider network that allows the Titan device to accept a maximum input of ± 32 volts.

Channel excitation and input divider functions, as well as gain and filter selection, and calibration and balance functions, are controlled by TCS.

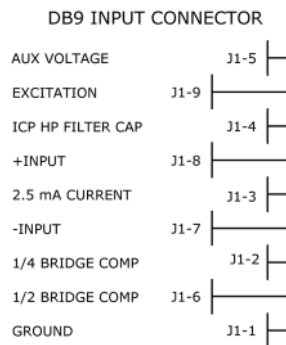

Bridge Completion

For quarter bridge and half bridge sensors, the Mini-Recorder's internal bridge completion circuitry creates an equivalent full bridge configuration when connected as shown (see Sensor Connection Examples, page 18):

For Quarter Bridge sensors:

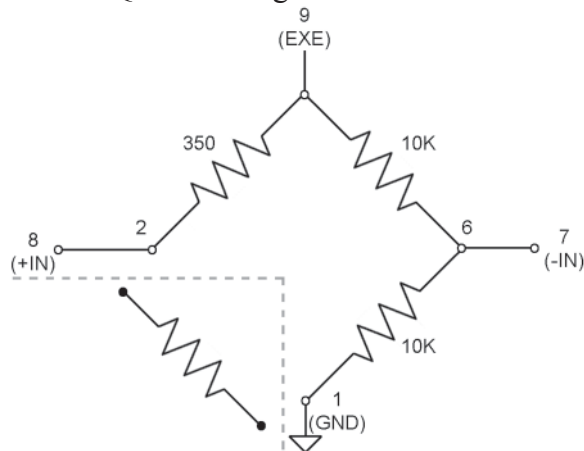

For Half Bridge sensors:

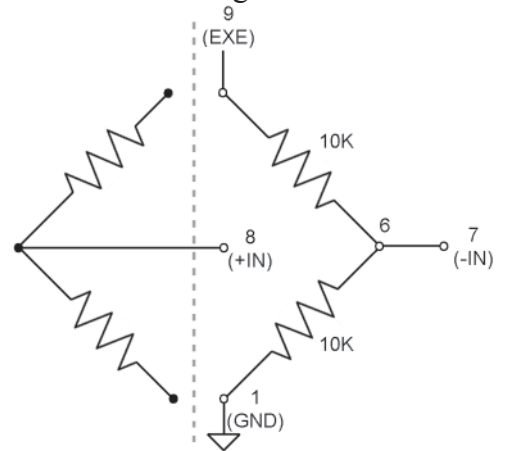

Calibration Modes

Calibration for the Titan BMS Mini-Recorder can either be activated from the panel switch or under control from TCS.

CAL+ and CAL-

Calibration modes CAL+ and CAL- activate either a shunt resistor on the sensor (if the calibration type for the channel is set to 'RCal'), or places a fixed voltage into the input (if the calibration type for the channel is set to 'VCal'). For VCal, the input is switched over to the CAL voltage (either positive or negative), while RCal maintains the input connection to the sensor, but switches in the shunt resistor.

Balance values (if any) are removed for VCal sensors, but maintained for RCal sensors.

CAL0

CAL0 mode activates a common mode short on the input of all channels, providing an indication of the system offset. Like the CAL+ and CAL- modes, the balance value for VCal sensors is removed, but is maintained for RCal sensors.

Formatting Memory Cards

New SD memory cards must be formatted for the Mini-Recorder prior to use. New memory cards should always be formatted *in the Mini-Recorder* using the following procedure:

1. If a memory card is inserted, eject the card and power cycle the Mini-Recorder.
2. In TCS, connect [F1] to the Mini-Recorder.
3. Insert the SD memory card.
4. In TCS, select ‘Format SD Card (Mini-Recorder)’ from the Device menu:

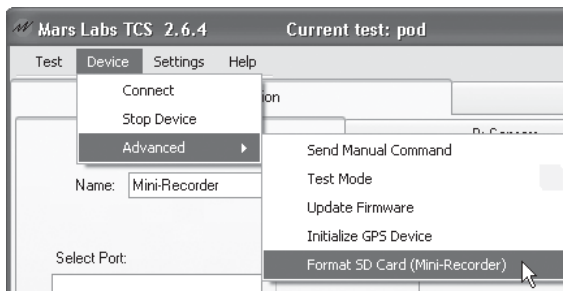

5. A warning message will be displayed:

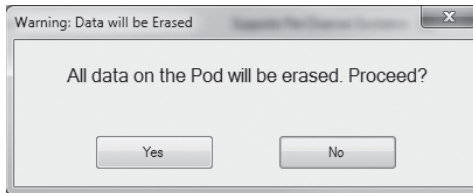

6. Click ‘YES’ to proceed and the card will be formatted. When finished, a ‘Format Complete’ message will be displayed:

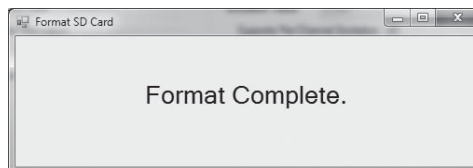

7. Close the message window and disconnect in TCS, or proceed with test configurations.

NOTES:

1. Memory cards up to 16GB (labeled ‘Ultra II’, ‘Extreme III’, or ‘Class 10’) supported.
2. The maximum file size that a Pod can handle is 2GB. If your anticipated acquisition approaches or exceeds this amount, enable File Partitioning under “Recording Options” in TCS and adjust the partition size to ‘1000M’ (1GB). File Partitioning breaks up large test files into small chunks; when the chunk size limit is reached, the file is closed out and stored, and a new file is opened. For more on File Partitioning, refer to the TCS User Manual.

This page intentionally left blank

Interface

Analog Input Connector (DB9F):

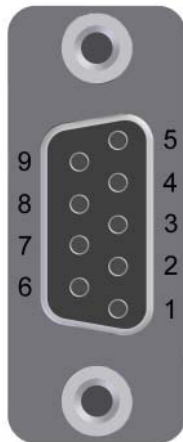

Pin Number	Function
1	Ground
2	Quarter Bridge (QB) Completion Resistor
3	Current source
4	ICP Capacitor
5	Secondary Auxiliary Voltage *
6	Half Bridge Bias
7	- Input
8	+ Input
9	Programmable Excitation

* If a voltage is applied to pin 4 of the Auxiliary Power Connector, this voltage appears on pin 5 on *all* input connectors.

COMM Port (RJ45):

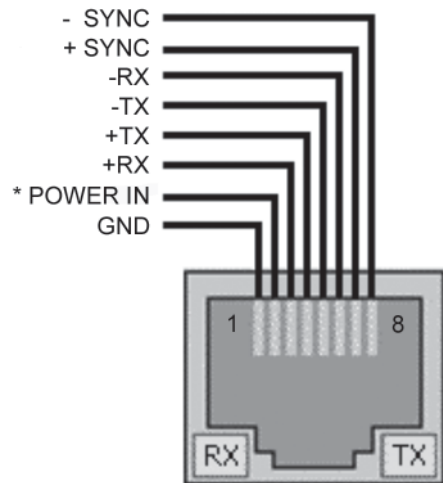

The POWER IN pin is internally configured at the factory for +5V, +12V or 0V. A label on the side nearest the COMM port connector displays the configuration.

NOTES: For information on configuring the COMM port for communication with TCS instead of using the USB port, refer to 'Running with RS-422' in the TCS User Manual

GPS Port:

The pinout of the GPS port appears below. The labels identify the signal lines coming *from* the GPS device.

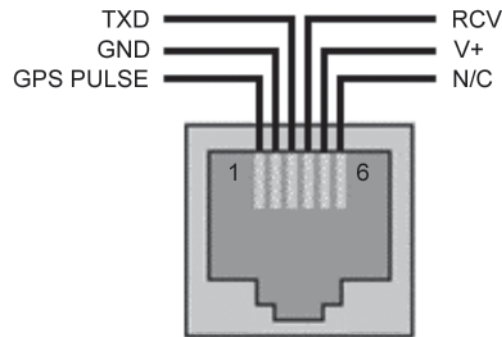

REM (Remote):

The REM jack allows the Mini-Recorder recording function to be started and stopped remotely by means of an external switch. It is implemented on an 1/8" TRS (Tip-Ring-Sleeve) jack that provides connection for an external switch and an LED indicator as follows:

Tip - Switch
 Ring - LED
 Sleeve - Ground

The Mini-Recorder will start recording when a switch closure is made between the Tip and Sleeve contacts. When the switch is placed in the open position, recording will stop. If an LED is connected between the Ring and Sleeve contacts, it will be illuminated when the Mini-Recorder is recording.

When a remote switch is used, it overrides the CONTROL panel switch for control of the recording function - you will not be able to enable or disable recording from the CONTROL panel switch. Calibrations, however, can still be activated from the CONTROL panel switch while the remote switch is in use.

NOTES:

1. Always remove power to the Mini-Recorder before plugging in a remote switch.
2. The REM jack is disabled when the Mini-Recorder is used with the Titan CPU.

Sensor Connection Examples

The following diagrams illustrate common sensor connections for the Titan BMS device.

Full Bridge Sensor

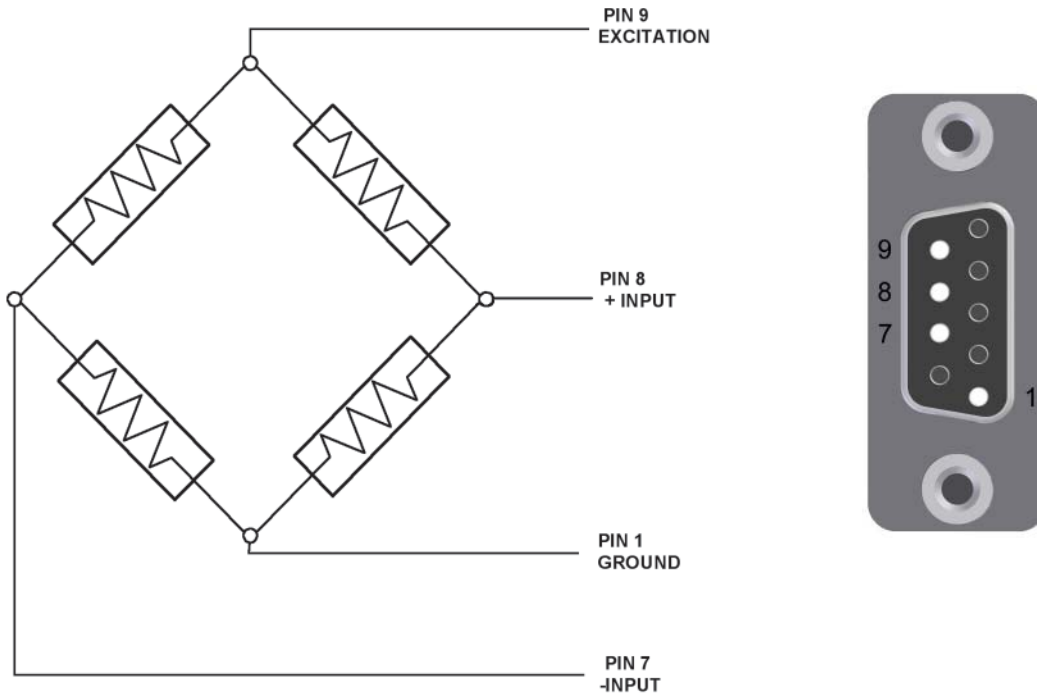

<i>Pin Number</i>	<i>Function</i>
1	Ground
2	Quarter Bridge (QB) Completion Resistor
3	Current source
4	ICP Capacitor
5	Auxiliary Voltage
6	Half Bridge Bias
7	- Input
8	+ Input
9	Programmable Excitation

NOTE: For Full Bridge configurations, the input dividers are set to OFF



See Guidelines for Wiring Sensors, page 6

Half Bridge Sensor

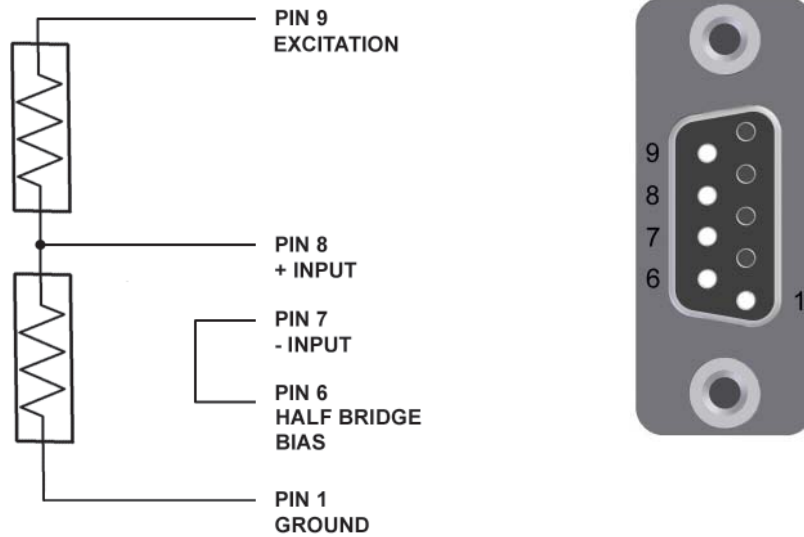

Pin Number	Function
1	Ground
2	Quarter Bridge Completion
3	Current source
4	ICP Capacitor
5	Auxiliary Voltage
6	Half Bridge Bias
7	- Input
8	+ Input
9	Programmable Excitation

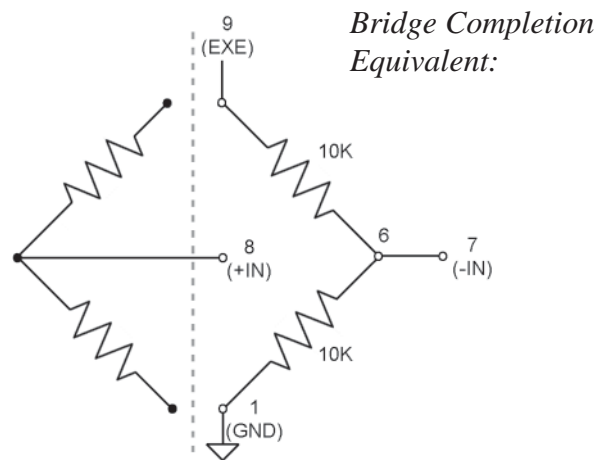

NOTE: For Half Bridge configurations, the input dividers are set to OFF



See Guidelines for Wiring Sensors, page 6

Quarter Bridge Sensor

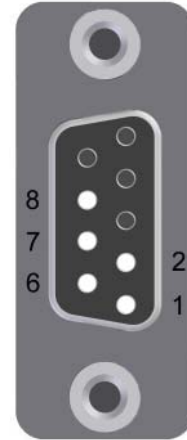
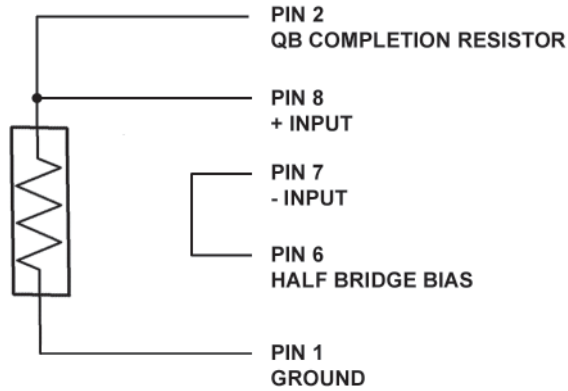

Pin Number	Function
1	Ground
2	Quarter Bridge Completion
3	Current source
4	ICP Capacitor
5	Auxiliary Voltage
6	Half Bridge Bias
7	- Input
8	+ Input
9	Programmable Excitation

Bridge Completion Equivalent:

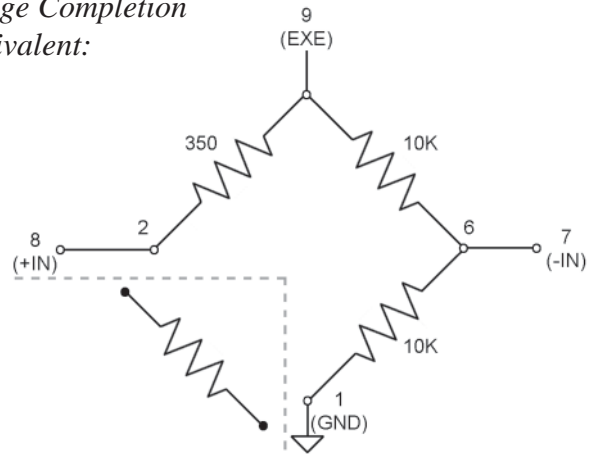

NOTE: For Quarter Bridge configurations, the input dividers are set to OFF



See Guidelines for Wiring Sensors, page 6

Platinum RTD Sensor

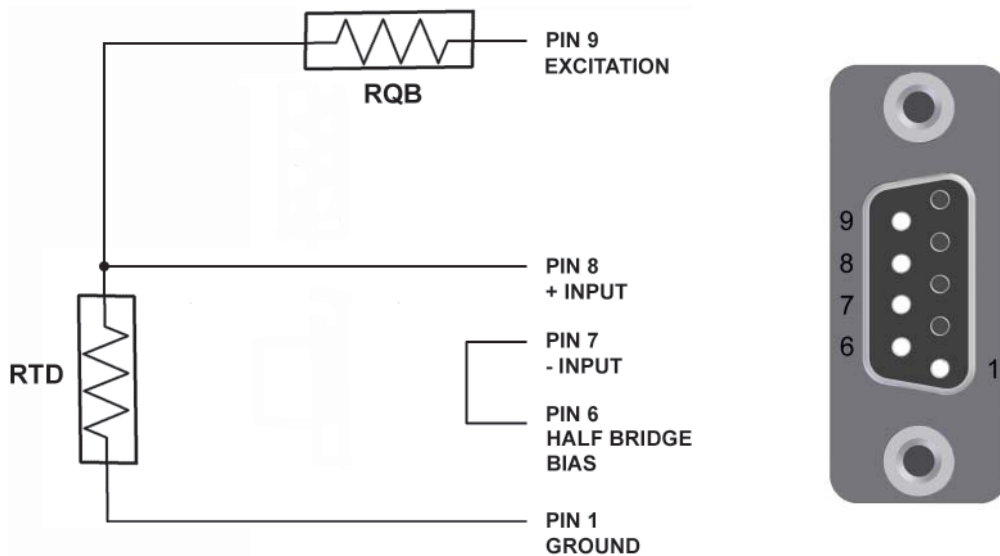

Pin Number	Function
1	Ground
2	Quarter Bridge Completion
3	Current source
4	ICP Capacitor
5	Auxiliary Voltage
6	Half Bridge Bias
7	- Input
8	+ Input
9	Programmable Excitation

Bridge Completion Equivalent:

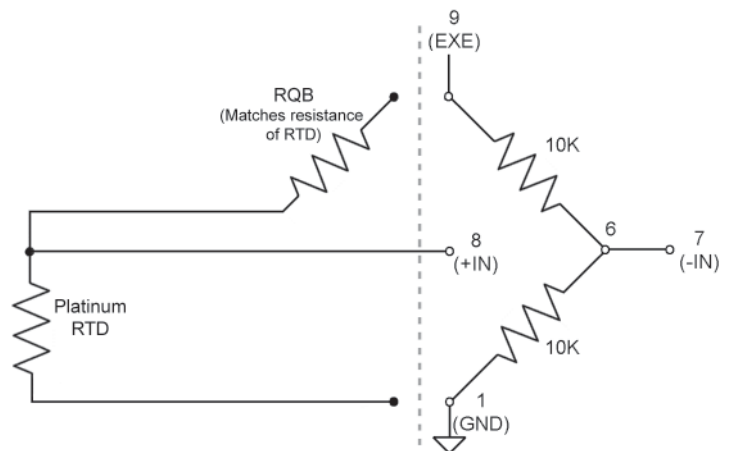

NOTE: For Platimun RTD configurations,
the input dividers are set to OFF



See Guidelines for Wiring Sensors, page 6

Voltage Sensor

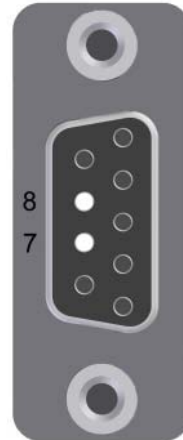
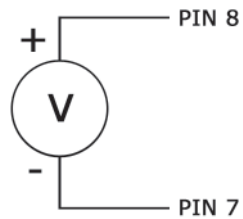

<i>Pin Number</i>	<i>Function</i>
1	Ground
2	Quarter Bridge (QB) Completion Resistor
3	Current source
4	ICP Capacitor
5	Auxiliary Voltage
6	Half Bridge Bias
7	- Input
8	+ Input
9	Programmable Excitation

NOTE: For Voltage Sensor configurations, the input dividers must be ON.



See Guidelines for Wiring Sensors, page 6

ICP Sensor

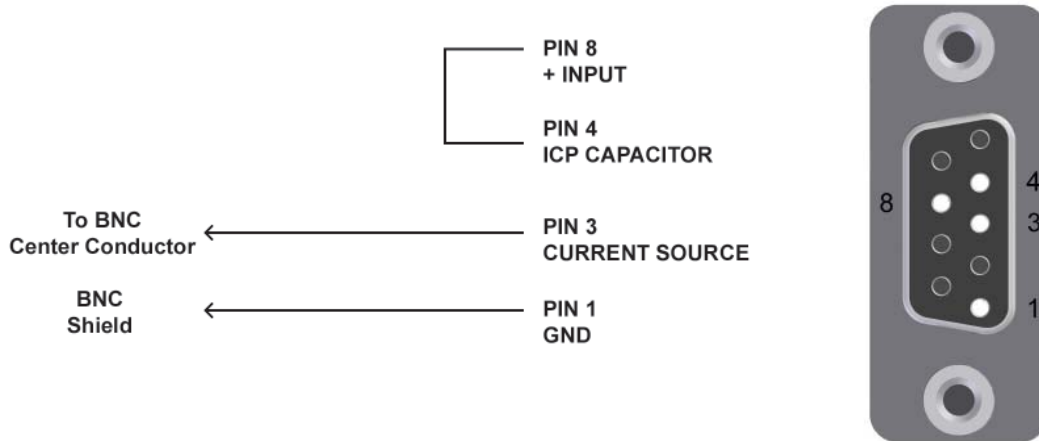

<i>Pin Number</i>	<i>Function</i>
1	Ground
2	Quarter Bridge (QB) Completion Resistor
3	Current source
4	ICP Capacitor
5	Auxiliary Voltage
6	Half Bridge Bias
7	- Input
8	+ Input
9	Programmable Excitation

NOTE: Older Titan AMS devices did not provide an internal ICP capacitor on pin 4; this capacitor had to be added externally to the ICP DB9/BNC adapter assembly between pin 8 and pin 3. Titan BMS devices provide an ICP capacitor on pin 4 and should be wired as shown. Titan ICP DB9/BNC adapters originally made for AMS devices can still be used without modifications on Titan BMS devices since they provide the required capacitor between pins 3 and 8.



See Guidelines for Wiring Sensors, page 6

String Pot Sensor (Cable Extension Transducer)

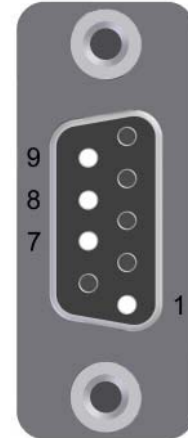
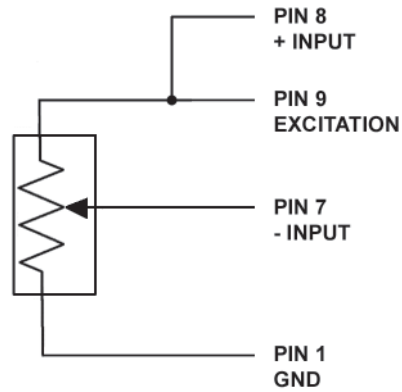

<i>Pin Number</i>	<i>Function</i>
1	Ground
2	Quarter Bridge (QB) Completion Resistor
3	Current source
4	ICP Capacitor
5	Auxiliary Voltage
6	Half Bridge Bias
7	- Input
8	+ Input
9	Programmable Excitation

NOTE: For String Pot Sensor configurations, the input dividers must be OFF



See Guidelines for Wiring Sensors, page 6

RVIT (Rotary Variable Inductive Transducer), 60 Degrees

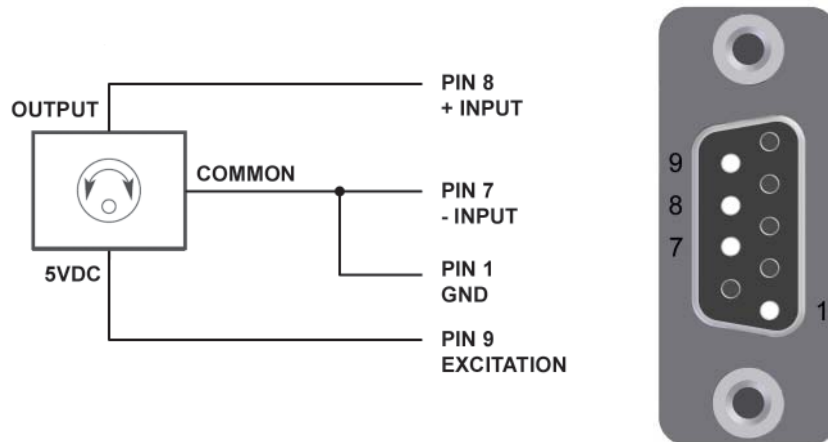

Pin Number	Function
1	Ground
2	Quarter Bridge (QB) Completion Resistor
3	Current source
4	ICP Capacitor
5	Auxiliary Voltage
6	Half Bridge Bias
7	- Input
8	+ Input
9	Programmable Excitation

NOTES:

1. For RVIT configurations, the input dividers are set to ON.
2. The configuration shown above is for the Schaevitz Sensors Model RVIT-15-60. For other RVIT sensors, consult the manufacturer's data sheet



See Guidelines for Wiring Sensors, page 6

Frequency Sensor

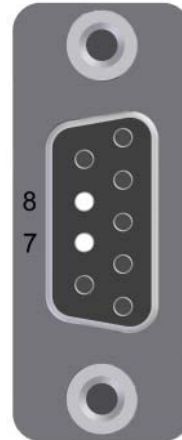
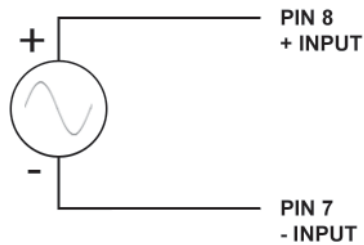

For frequency sensor inputs:
 TCS GAIN > 4
 Input Signal > 4Vpp

Pin Number	Function
1	Ground
2	Quarter Bridge (QB) Completion Resistor
3	Current source
4	ICP Capacitor
5	Auxiliary Voltage
6	Half Bridge Bias
7	- Input
8	+ Input
9	Programmable Excitation

NOTES:

1. Frequency sensors are only supported on channels 1, 8, & 16; only one frequency sensor may be used at a time.
2. Frequency sensor measurements are valid to approximately 7K Hz.



See Guidelines for Wiring Sensors, page 6

Thermocouple Sensor

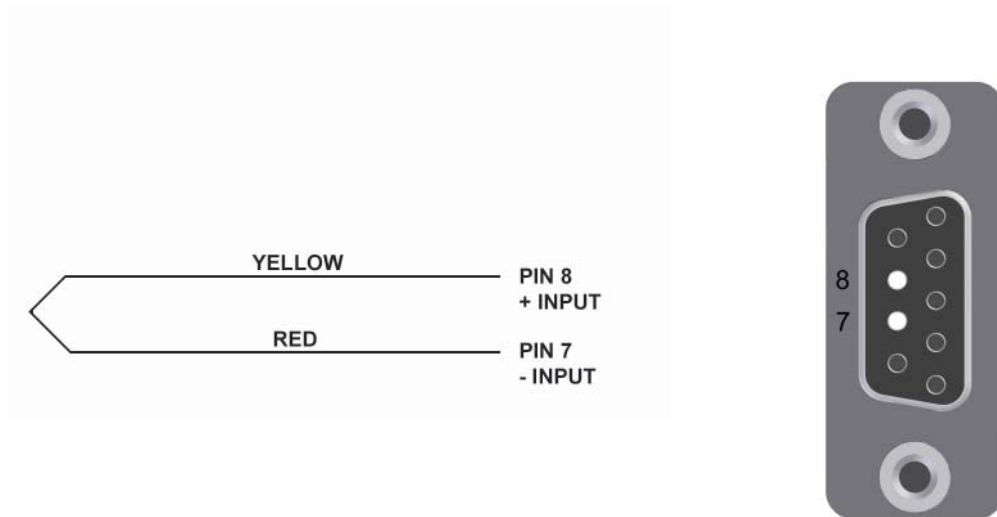

Note: Colors shown are for a K type thermocouple

<i>Pin Number</i>	<i>Function</i>
1	Ground
2	Quarter Bridge (QB) Completion Resistor
3	Current source
4	ICP Capacitor
5	Auxiliary Voltage
6	Half bridge Completion
7	- Input
8	+ Input
9	Programmable Excitation

NOTE: For Thermocouple configurations, recommended TCS Channel Gain = 32.

For more information on using Thermocouples with Titan Mini-Recorders, refer to the *Theory and Operation of Thermocouples* on page 28.



See Guidelines for Wiring Sensors, page 6

Theory and Operation of Thermocouples

This section will address the theory and operation of thermocouples in real-world applications.

A thermocouple consists of a junction between two different metals that produces a voltage related to temperature. All dissimilar metal junctions exhibit this phenomenon, called the “Seebeck effect”. One common thermocouple is the T-Type, which is shown below:



Figure 1. Thermocouple Junction

The voltage on the Copper and Constantan (Cu and C, respectively) leads is related to the temperature of the junction J1 by a polynomial in general, and linearly when the temperature range is small. Connection of those Cu and C leads directly to a copper volt-meter results in one additional junction between the Constantan of the Thermocouple and Copper lead of the Meter, as seen below at junction J2 (J3 is Cu-Cu, which results in zero voltage):

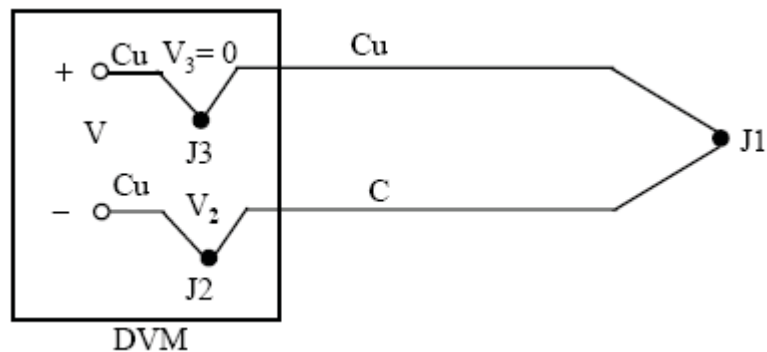

Figure 2. Thermocouple attached to a Digital Volt Meter

Compensation for this additional junction is accounted for within the Titan devices, the details of which are outside the context of this discussion.

The purpose of this discussion is to emphasize the sensitivity of the measurement to external effects. By extending the thermocouple with regular hookup wire, for instance, an additional junction is created between the thermocouple and the hookup wire. This will lead to an error in the

measurement unless some compensation for the junction is made. Additionally, by placing the junction J1 in an environment that may affect its output voltage such as in an electrolytic solution, the thermocouple may report misleading values. Finally, connection of the thermocouple to some conductive surface may or may not be of concern. Should that surface have any electrical path back to the Titan Thermocouple device such as a common ground, voltage readings from the thermocouple may be unreliable. **These concerns suggest that any and all electrical isolation (galvanic isolation) precautions should be taken when installing a thermocouple.** The material used to isolate the thermocouple should depend on the application. In most applications where temperatures are within -55 to 260 degrees C, non-conductive epoxy such as J-B Weld may be used. In more extreme temperatures, applications may call for specialty epoxy or cement. For example, if the temperature event under study is very fast the method of isolation must be very quick to change temperature. Omega Engineering sells thermally conductive cement called OmegaBond that is electrically isolating and suitable for such uses. Thin coats of this cement may be applied to thermocouples to isolate them electrically while allowing high thermal conductivity. This cement is suitable for high temperature applications. For more information on OmegaBond, go to:

http://www.omega.com/ppt/pptsc.asp?ref=OB_BOND_CHEM_SET&Nav=temf08

Thermocouples are available in several variants. *Titan Mini-Recorder* devices support **J**, **K**, and **T** type thermocouples (only one type of thermocouple may be used at a time). The table below displays the temperature ranges and related connection information for the three supported thermocouple types.

Type	Temp Range (C)	Positive (+) Lead	Recommended TCS Gain
K	-180 to +1300	Yellow	32
J	-180 to +800	White	32
T	-250 to +400	Blue	32

In summary, when using thermocouples:

- 1) Electrically isolate thermocouples from the environment in which they are used
- 2) Minimize isolation mass around thermocouple when concerned with high-speed temperature events
- 3) Use the appropriate thermocouple for the application
- 4) Use appropriate thermocouple hookup or extension cabling for the type of thermocouple in use
- 5) Always observe the polarity of connections

Per-Channel Excitation

The Titan BMS Mini-Recorder supports a ‘per-channel excitation’ feature that permits individual sensor excitation voltages to be applied for each channel. This feature is available for nine sensor types (Load, Strain, Displacement, Pressure, Full-Bridge Accelerometer, Solid State Accelerometer, Sensitivity, Polynomial and Voltage), and is programmable over a range of 2-11.5 volts. Per-channel excitation is configured through the Titan Control Software.

NOTE: When sensor excitation is enabled, the Titan Mini-Recorder **must** be powered from the Auxiliary Power Input.

To configure per-channel excitation, follow these steps:

1. In TCS, on the *Device Configuration* page, check the “Supports Per-Channel Excitation” checkbox:

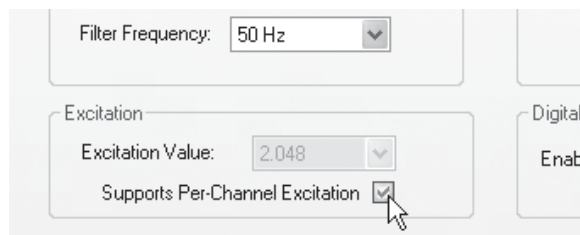

2. On the *Sensors* page, select the desired sensor type (a ‘Voltage’ sensor type is used for this example). Set the excitation source to ‘Internal’ and select the desired Excitation Value from the drop-down menu.

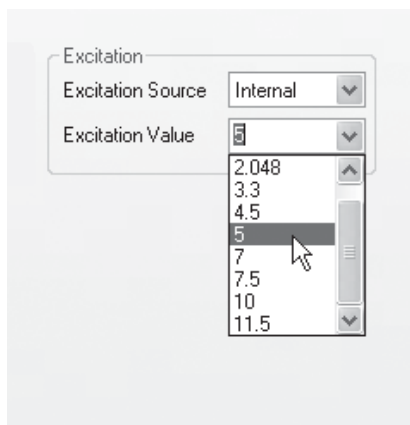

NOTE: When the Excitation Source is set to ‘Internal’, the excitation voltage is sourced from the Titan hardware. When the Excitation Source is set to ‘External’, excitation **must** applied to the sensor from an external source. Whenever external excitation is applied, the Excitation Value should be set to match this voltage.

3. On the *Tags & Channels* page, select the sensor that was just configured on the *Sensors* page and assign it to a channel. TCS will determine the range and resolution for the given sensor parameters:

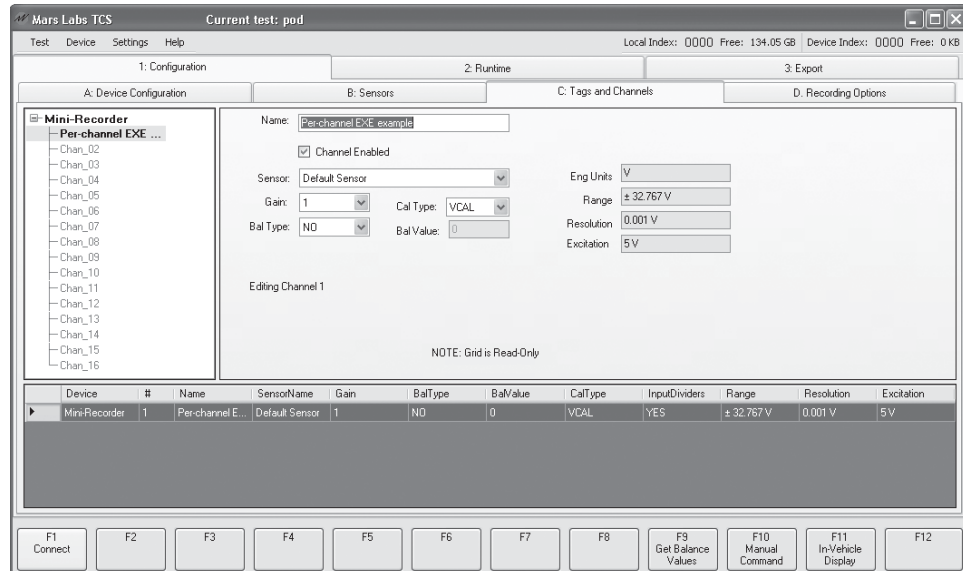

4. On the Titan hardware, the Excitation voltage (EXE) appears on pin 9 of the DB9 connector. To configure a simple loopback circuit to monitor the excitation voltage in TCS, jumper the pins as shown:

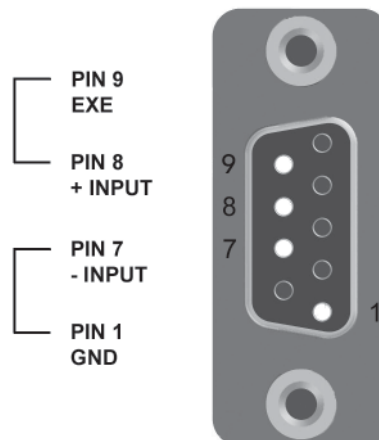

5. With the loopback in place, switch to the Runtime environment in TCS and begin scanning ('F3'); the selected excitation voltage value can be viewed on the TCS *Single Pod Monitor* screen:

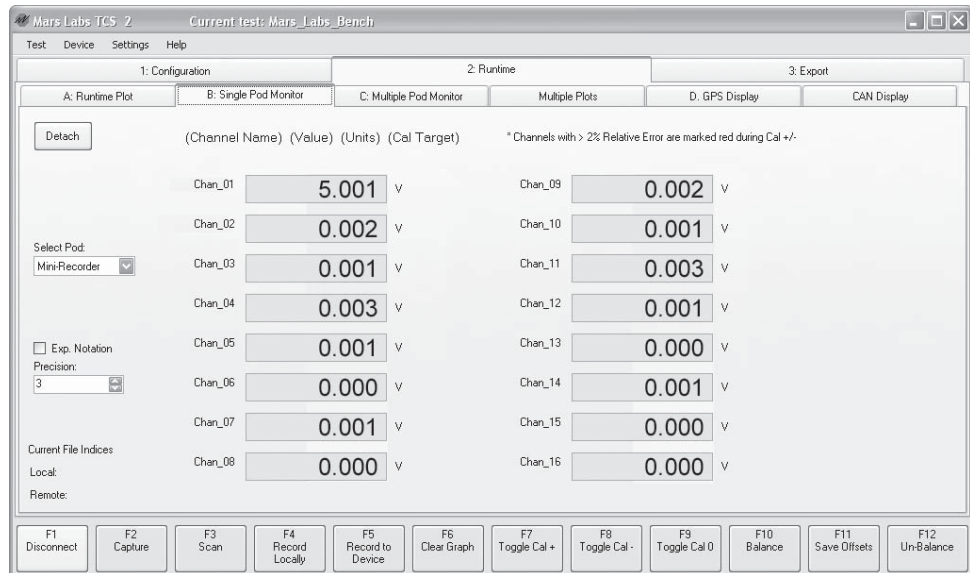

Features and Specifications

Key Features

- Supports multiple modes of operation:
 - Standalone recording up to 16 channels
 - Connected to a PC recording up to 16 channels
 - Connected to an 8-port Titan CPU for up to 128 channels
- High performance analog front-end with full Balance and Calibration loopback features.
- Lightweight, portable unit suitable for in-vehicle applications.
- Sensor input connections via industry-standard D-sub connectors
- Simplified user interface provides easy operation under difficult operating conditions.
- Sample rates up to 1200 Hz/channel (Low Speed) or 10,000 Hz/channel (High Speed)

Specifications

Number of Channels	16 fault-tolerant channels on DB9F connectors
Calibration Modes	Resistive (Rcal): $\pm 100K$ Ohms per channel (shunt calibration) Voltage (Vcal): Precision positive and negative calibration voltages
Bridge Completion	Provided for 350 ohm Quarter and Half bridge sensors
Excitation Value and Current	Precision per-channel programmable, 2 to 11.5 Volts at 25mA with per-channel overload protection
Resolution	Utilizes 24-bit A/D converters; 16-bit exported
Programmable Gain	From $\pm 1/16$ to ± 512 ; Full scale input voltage up to $\pm 32V$
Programmable Filter	8 pole Butterworth for scan rates up to 1200 samples/sec 10 pole Linear Phase for scan rates up to 10,000 samples/sec
Sensors Supported	See table, page 34
Recorder Option	Records data to Secure Digital memory card. Supports SD cards up to 16 GB.
PC Operation	Remote recording and control via USB
Stand-alone operation	Via on-board switches or with a wired remote switch
GPS (Auxiliary Digital Input)	Support for the Garmin GPS 18X 5Hz with PPS Digital Input support via Titan External Digital Pod
Expansion Slot (1)	Support for optional Internal DAC (analog output) or Internal Digital Pod (digital input) expansion card
Power Requirements	11-32 VDC 3W (base unit, sensors not driven)
Dimensions / Weight	17.4 cm x 10.6 cm x 3.7 cm (L x W x H) / 540g

Supported Sensors

Analog

The table below shows the types of analog sensors supported by the Titan BMS Mini-Recorder.

Titan Device Type	Input Connector	Analog Sensors Supported					
		Strain Gauge		TC ¹	Differential Voltage ±32V	ICP	Tach ²
		F/H/Q Bridge	Bridge Comp.				
BMS	(16) DB9	16	Y ³	16	16	16 ⁴	1

NOTES:

1. Support Thermocouple types J, K & T.
2. Supports Tachometer frequencies up to 7KHz. Digital sensors (Period or Frequency sensors) are only supported on channels 1, 8 and 16, and only one sensor can be used at a time.
3. Bridge completion resistor = 350 ohm
4. Current = 2.5mA

Digital

Via an External or Mini-Digital Pod, the Titan BMS Mini-Recorder provides digital sensor support for SAE J1939, ISO 15765 (ECU CAN), GPS (Garmin 18X-5Hz), IMU (3DM-GX3), and multiple WFT protocols including Kistler and Michigan Scientific.

Titan Nomenclature

The Titan family of input modules offer a wide range of configuration options. Titan device configurations are specified by the part number in the following format:

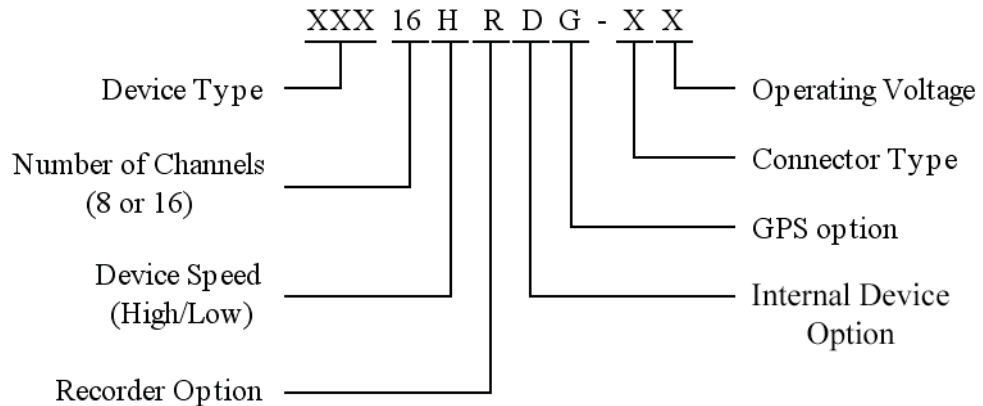

Titan Device Type:

BMS – ‘B’ Series Multi Sensor

Internal Device Option:

‘A’ – Internal DAC Expansion Card

‘D’ – Internal Digital Pod Expansion Card

Connector Type:

Input connector options are dependant on the Titan device type.
Consult the factory for more information.

Operating Voltage:

‘1’ – for 12 volt devices

‘2’ – for 24 volt devices

‘3’ – for wide input range devices (11 - 32V)

Asset Tag/Customer Information Data Entry

Titan Mini-Recorder firmware (v0.31.10 and higher) permits user-entry and storage of asset tag and other customer-specific information on the device. A dedicated 'Asset Tag' field permits entry of up to 15 characters, while a dedicated 'Customer Information' field supports up to 31 characters. Once the information is entered, these fields can be locked to prevent changes or tampering. The information is entered using the Manual Command window in TCS using the commands listed below.

To use the commands:

1. Determine beforehand what information will be entered in these fields.
You may enter up to 15 characters (not including the asterisk [*]) for the Asset Tag field.
You may enter up to 31 characters (not including the asterisk) for the Customer Information field.
Character strings may not include a colon (:), a Carriage Return <CR> or a Line Feed <LF>.
2. Enter the Asset Tag information as defined, adding an asterisk to the end of the string as shown below. *Do not set the lock.*
3. Enter the Customer Information as defined, adding an asterisk to the end of the string as shown below. *Do not set the lock.*
4. Using the GET_ASSET_TAG and GET_CUSTOMER commands, confirm that the assigned field values are correct.
5. Issue the SET_ASSET_LOCK command. The Asset Tag and Customer Information fields will then be permanently stored on the device and can be accessed at any time using the GET commands.

The Commands

SET_ASSET_TAG

Syntax: SET_ASSET_TAG<space><15 char string>* <send>
Summary: Fills the Asset Tag field with up to 15 characters
Valid Inputs: <15 char string>
Example: SET_ASSET_TAG ABC-123*
Valid Outputs: ACK, ERROR

GET_ASSET_TAG

Syntax: GET_ASSET_TAG <send>
Summary: Returns the Asset Tag character string
Sample Output: "ABC-123"

SET_CUSTOMER

Syntax: SET_CUSTOMER<space><31 char string>* <send>
Summary: Fills the Customer Information field with up to 31 characters
Valid Inputs: <31 char string>
Example: SET_CUSTOMER My Titan BMS Device*
Valid Outputs: ACK, ERROR

GET_CUSTOMER

Syntax: GET_CUSTOMER <send>
Summary: Returns the Customer Information character string
Sample Output: "My Titan BMS Device"

SET_ASSET_LOCK

Syntax: SET_ASSET_LOCK <send>
Summary: Permanently locks the Asset Tag and Customer Information fields.
Warning: Once used, this command cannot be undone!
Example: SET_ASSET_LOCK
Valid Outputs: ACK, ERROR

GET_ASSET_LOCK

Syntax: GET_ASSET_LOCK <send>
Summary: Returns the state of the Asset Tag and Customer Information field locking mechanism.
Sample Output: "LOCKED", "UNLOCKED"

Troubleshooting

If you are having difficulties configuring, connecting or using your Titan device, refer to the troubleshooting section below. This section addresses common issues with the operation of Titan devices. If your specific issue is not addressed, please contact the factory for additional assistance.

Issue: No power

After connecting the Titan device via USB, the Power LED does not illuminate (no power).

Solution

Titan devices use a special ‘Y’ cable to provide power from two USB ports. Both USB cable connections must be in place - a single connection may not supply sufficient power. If both USB connectors are plugged in and the Titan device still isn’t powered, try connecting to another USB port pair on the host PC. If the problem persists, try applying power to the Titan device through the Auxiliary Power Connector. If the Titan device still isn’t working, contact the factory for additional support.

Issue: Windows holds port open

If you fail to disconnect in TCS before physically disconnecting or powering down the Titan device, Windows holds that port open. When you reconnect, the port appears twice in the *Select Port* field in TCS.

Solution

Click ‘Disconnect’ in TCS. Physically disconnect the Titan device. In TCS, click ‘Query Serial Devices’. This will clear the *Select Port* field and unlock the COMM port.

Issue: Windows won’t recognize the Titan device when using a DAC

If you are using a Titan DAC with a new installation of TCS, Windows does not recognize the hardware.

Solution

This can happen if the Titan device drivers are not installed. Remove the DAC temporarily from the configuration and plug the Titan device directly into USB. The Windows ‘Hardware Install’ wizard will recognize that new hardware is connected and begin the driver installation process. Allow this process to complete before reconnecting the DAC.

Issue: SD Card not recording data/recording wrong data

The SD card doesn't record data, or the SD card appears to be recording data incorrectly.

Solution

To record data properly to an SD card, the Titan device must be loaded with the current test file parameters. If an old test file configuration is used, the data can appear to be corrupted or invalid. To download the current test file, you must be connected [F1] to TCS. Configure the test parameters in TCS, then go to the 'Runtime' tab and click 'SCAN'. TCS will download the current test file parameters to the Titan device.

Issue: Cannot record remotely

You cannot record remotely to the Titan device.

Solution

Check to make sure that an SD memory card is properly inserted in the SD memory card slot. Titan devices accept Ultra II, Extreme III, or Class 10 SD cards up to 16GB (Sandisk cards recommended). If a known-good card is properly installed and you still can't record, check to make sure that there is free memory available. Titan devices will not go into remote recording mode if no free space is available on the SD card.

Issue: Cannot record remotely when connected to a Titan CPU

You cannot record remotely when the Titan device is connected to a Titan CPU.

Solution

This is normal operation. When the Mini-Recorder is connected to the CPU, the Mini-Recorder remote recording function is disabled on both panel switch and the remote recording jack.

Issue: Remote acquisitions larger than 2GB result in an error

Files larger than 2GB do not show up properly when "Browse Device" is selected in the 'Browse Remote Files' tab.

Solution

The maximum file size that a Pod can handle is 2GB. If your anticipated acquisition approaches or exceeds this amount, enable File Partitioning under "Recording Options" in TCS and adjust the partition size to '1000M' (1GB). File Partitioning breaks up large test files into small chunks; when the chunk size limit is reached, the file is closed out and stored, and a new file is opened. For more on File Partitioning, refer to the TCS User Manual.

Issue: “A device attached to the system is not functioning” error

When attempting to connect through TCS to a device that is connected via USB *before* Auxiliary Power is applied, TCS may report an error message:

“A device attached to the system is not functioning”

Solution

To correct the error, perform the following steps:

- a. Disconnect from TCS
- b. Disconnect the USB cable from the Mini-Recorder and remove Auxiliary Power.
- c. Apply Auxiliary Power, allowing the device to initialize, and then remove power.
- d. Apply Auxiliary Power and allow the device to initialize
- e. Reconnect the USB cable
- f. Connect to the device through TCS

To prevent this issue from reoccurring when powering the Mini-Recorder with Auxiliary Power:

- a. Apply Auxiliary Power before connecting to USB.
- b. Remove USB before removing Auxiliary Power.

Issue: No excitation under USB power

The Pod does not provide excitation when powered via USB, but when powered externally, excitation is present.

Solution

This is normal operation. When excitation is enabled, the Pod must be powered by the external power source.

Older “A” series models were capable of providing excitation when powered via USB because they supplied a single excitation voltage of 2.048 VDC. The newer “B” series models now offer per-channel excitations up to 11.5VDC. For these newer models, there is not enough USB power available when excitation is enabled, thus external power must be applied through auxiliary voltage connector.

Warranty

Mars Labs warrants all their manufactured equipment to be free from defects in material and workmanship. **Mars Labs** liability under this warranty is limited to servicing or adjusting any equipment returned to the factory for that purpose, and to replace any defective parts thereof. The warranty remains effective for 365 days following delivery to the original purchaser. During this time, equipment will only receive repair when the original purchaser prepays all return transportation charges, and **Mars Labs** finds to its satisfaction that the equipment is indeed defective.

If the fault has been caused by misuse or abnormal conditions of operation, normal service charges will prevail. In this case, an estimate will be submitted before work is started. **Mars Labs** must authorize any warranty returns.

Mars Labs reserves the right to make changes in the design of its instruments without incurring any obligation to make the same changes on equipment previously purchased.

This warranty will be void if unauthorized alterations or modifications are found which impede the repair or testing of the equipment.

Receipt of Equipment

The equipment should be tested as soon as it is received. If the equipment is damaged in any way, a claim should be obtained by the claim agent, and this report should be forwarded to **Mars Labs**.

Mars Labs will then advise the customer of the disposition to be made of the equipment and arrange for repair or replacement. When referring to this equipment for any reason, the model number, serial number and purchase order number should be included.

Malfunction

If the unit fails to operate, or any fault develops, **Mars Labs** should be notified, giving full details of the difficulty, including model number and serial number. Upon receipt of this information, **Mars Labs** will provide service data and shipping instructions.

This warranty is expressly in lieu of all other obligations or liabilities on the part of **Mars Labs**, which neither assumes nor authorizes any person to assume for it any other liability in connection with the sale of its equipment. Contact:

Mars Labs
29 C Street
Laurel, MD
20707
(301) 470-3278
email: Support@MarsLabs.com

Notes & Known Issues

This section offers additional operational information about the Titan Mini-Recorder not covered elsewhere.

Known Issues:

General:

The Mini-Recorder will stop running if scanning with USB enumerated but not connected/opened in either TCS or a terminal emulator.

High Speed Issues at 10KHz:

If the Mini-Recorder is connected via USB while recording remotely to the SD card, it will support a maximum of 12 channels at the 10KHz scan rate. If full 16-channel operation with a USB connection with remote recording is desired, select 8192 or a lesser scan rate.

Using SD memory cards other than the one supplied:

New memory cards must be formatted prior to use. Use 'Ultra II' or 'Extreme III' type cards only. See "Formatting Memory Cards" on page 14.

GPS Issues:

1. When GPS is enabled, at least one analog channel must also be enabled.
2. GPS does not operate correctly at the 10K Hz scan rate.
3. GPS output does not currently include northing and easting data.

Calibration:

Calibration values deviate by a factor of 2 for a gain of 256, and by a factor of 4 for a gain of 512 (only applies to firmware versions 0.34.23 and earlier).

In-Vehicle:

For in-vehicle applications, if the Mini-Recorder is powered from the vehicle and running when the vehicle is started, the device may require power-cycling.

Remote Recording / Remote Switch Operation disabled:

When a Mini-Recorder is connected to a Titan CPU as a part of a large data acquisition system, remote recording and remote switch operation is disabled on the Mini-Recorder. These functions are automatically re-enabled when the Mini-Recorder is reconnected to TCS in a stand-alone configuration *and* a scan is initiated from the Runtime screen.

Remote File Transfer via COMM not supported at the 3M Baud Rate

Mini-Recorder remote file transfers via the COMM connector are not supported at the 3M baud rate. If you attempt to transfer remote files at the 3M baud rate, TCS will produce an error. To transfer data files from the SD card, either change the baud rate to 921,600, or eject the SD card and use a card reader. Note that for large data files (>400 Mb) the recommended method is to use an SD card reader (transfer of large data files from the Mini-Recorder via other methods is much slower and can result in errors).

Issues with USB connectivity on Windows 7/8 PCs

If you are using a Windows 7 or Windows 8 PC and are experiencing USB connectivity issues, Mars Labs recommends updating your firmware to the latest version that is appropriate for your device. Contact the factory for more details.

Digital Pod Issues

When using a Digital Pod with a full load, i.e., two CAN Channels, a GPS, and IMU, in Low Speed mode at 1024 or 1200 Hz, you cannot remotely record *while* the device is connected over USB and scanning. Attempting to do this will cause a failure and the device will have to be power-cycled to restore normal operation.

